

# Thermodynamics of Brownian Ratchets

Reem Mokhtar

Edited by John Reif

# Thermodynamics

- **First law of thermodynamics:** the change in the internal energy of a closed system is equal to the amount of heat supplied to the system, minus the amount of work done by the system on its surroundings.  
  
→ The law of conservation of energy can be stated: The energy of an isolated system is constant.
- **Second law of thermodynamics:** The entropy of any isolated system not in thermal equilibrium always increases.
- **Third law of thermodynamics :** The entropy of a system approaches a constant value as the temperature approaches zero, which implies that it is impossible for any procedure to bring a system to the absolute zero of temperature in a finite number of steps

# Maxwell's Demon

This is a thought experiment created by physicist James Maxwell.

Why on earth would he do that?

Well, he was trying to say that the second law of thermodynamics wasn't ABSOLUTELY certain → it only has statistical certainty.

So, again, it tries to violate this second law (this is getting personal).

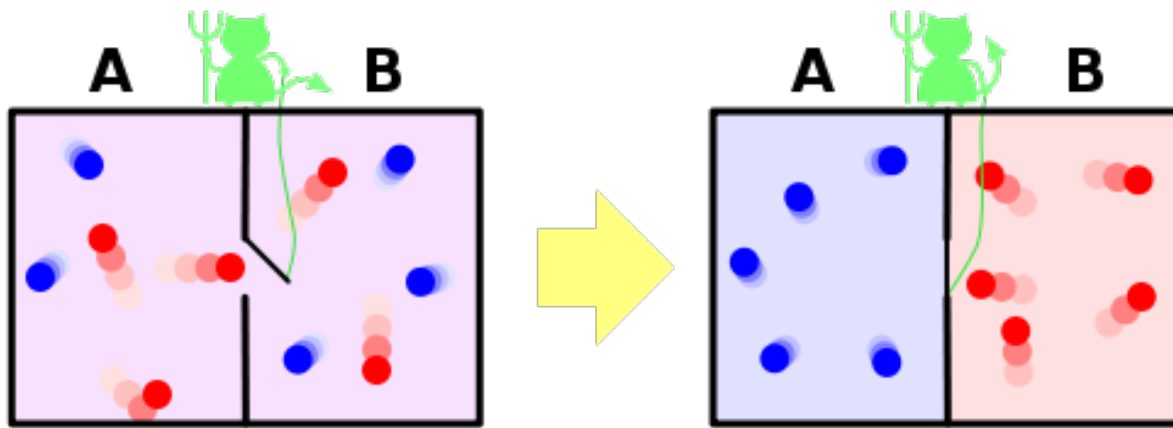

From Wikipedia: [http://en.wikipedia.org/wiki/Maxwell's\\_demon](http://en.wikipedia.org/wiki/Maxwell's_demon)

Another fun explanation at [http://alienryderflex.com/maxwells\\_demon.shtml](http://alienryderflex.com/maxwells_demon.shtml)

# Maxwell's Demon

Imagine that you have two compartments: one with hot and the other cold water.

If both compartments were to be mixed together, you'd reach an equilibrium, right?

OK, but what if you had this little pesky hypothetical being (let's call it a demon) that can open and allow molecules through to reverse this mixing/equilibrium process, but without expending energy and separating hot from cold by only allowing molecules hotter-than-average through to one side through a 'door'.

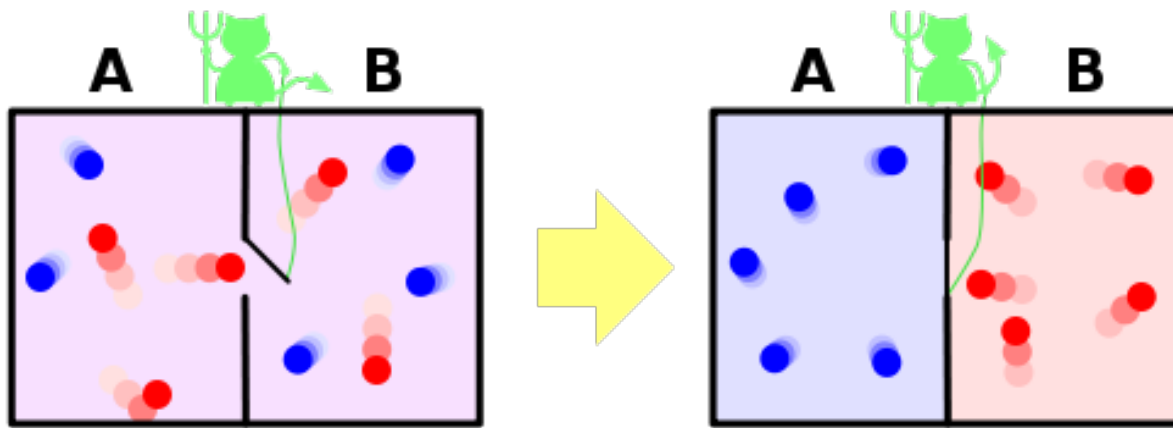

Check out the new experiment that 'converts information to pure energy'

<http://www.livescience.com/8944-maxwell-demon-converts-information-energy.html>

# Maxwell's Demon

In other words, going from a disordered (higher entropy) to an ordered system (lower entropy) without expending energy.

**This violates the second law of thermodynamics...which says what?**

- entropy should not decrease in an isolated system
- *It is impossible for a device to receive heat from a single reservoir and do a net amount of work.*
- *it is impossible to extract directed motion from a random process (a single heat reservoir).*
- *It is impossible to extract an amount of heat  $Q_H$  from a hot reservoir and use it all to do work  $W$ . Some amount of heat  $Q_C$  must be exhausted to a cold reservoir. This precludes a perfect heat engine.*

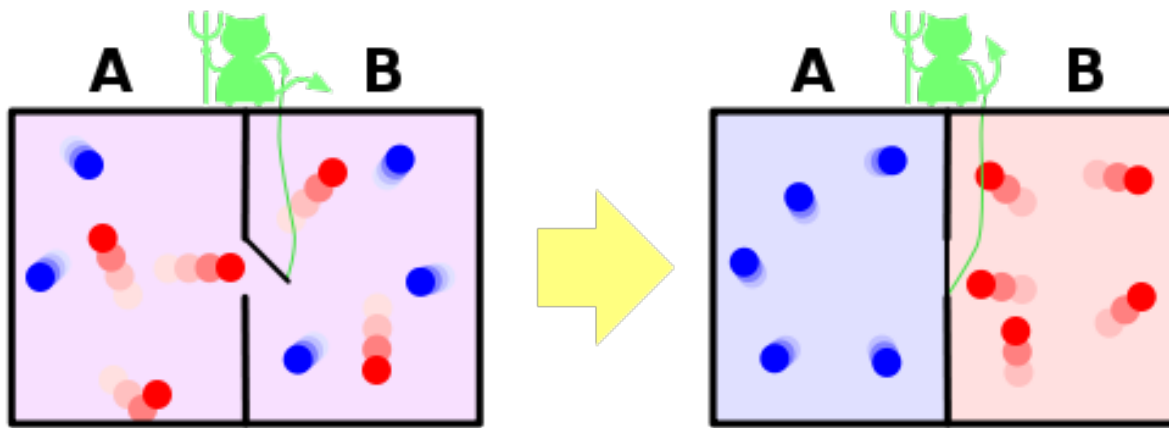

Check out the new experiment that 'converts information to pure energy'

<http://www.livescience.com/8944-maxwell-demon-converts-information-energy.html>

# Maxwell's demon - **Implications**

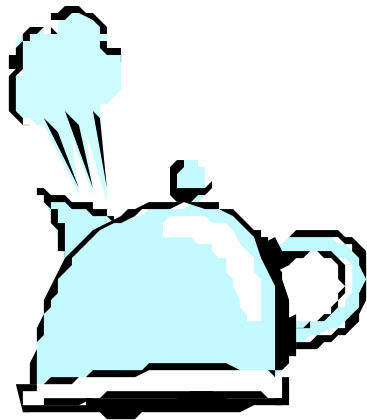

W. Smoluchowski (1941): **No Perpetual Motion Machines**

No automatic, permanently effective perpetual motion machine can violate the second law by taking advantage of statistical fluctuations

(Feynman: the demon is getting hot). Such device might perhaps function if operated by intelligent beings.

W.H. Zurek, Nature **341**(1989)119:

The second law is safe from intelligent beings as long as their abilities to process information are subject to the same laws as these of universal Turing machines.

# Brownian Ratchet

(A.F. Huxley '57)

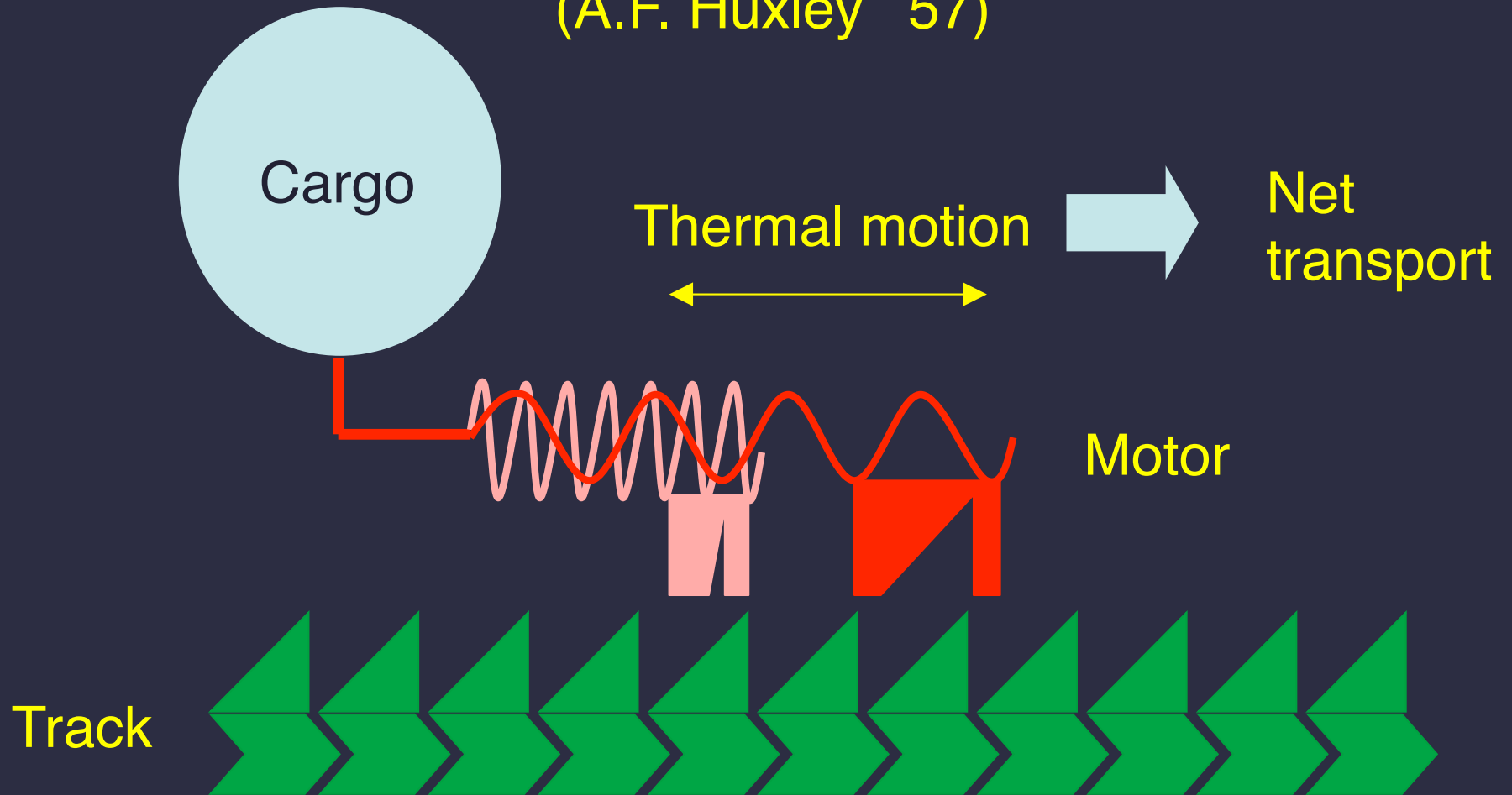

perpetuum mobile? Not if ATP is used to switch the off-rate.

# What is a Ratchet?

A device that allows a shaft to turn only one way



[http://www.hpcgears.com/products/ratchets\\_pawls.htm](http://www.hpcgears.com/products/ratchets_pawls.htm)

Feynman, R. P., Leighton, R. B., & Sands, M. L. (1965). *The Feynman Lectures on Physics: Mechanics, radiation, and heat* (Vol. 1). Addison-Wesley.

# The Ratchet As An Engine

## Ratchet, pawl and spring.

Let us try to invent a device which will violate the Second Law of Thermodynamics, that is, a gadget which will generate work from a heat reservoir with everything at the same temperature. Let us say we have a box of gas at a certain temperature, and inside there is an axle with vanes in it. (See Fig. 46-1 but take

First, our idealized ratchet is as simple as possible, but even so, there is a pawl, and there must be a spring in the pawl. The pawl must return after coming off a tooth, so the spring is necessary.

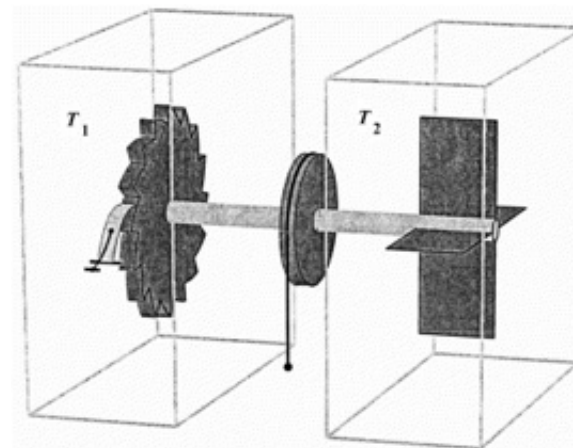

# Feynman's Brownian Ratchet Motor

Feynman's (Brownian) ratchet: what is it and what was the point of explaining it?

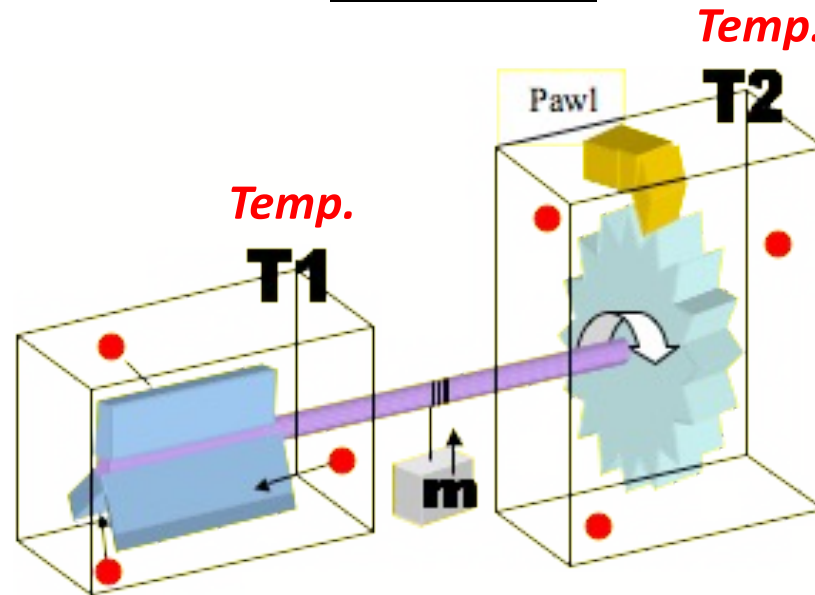

1. Rod
2. Paddle wheel: the fins on the left
3. A pawl: that yellow thing that forces the ratchet not to go back in the other direction
4. A ratchet: that saw toothed gear on the right
5. A spring/bearing (m) low friction, to allow rotation.

(From the fun explanation @:

<http://gravityandlevity.wordpress.com/2010/12/07/feynmans-ratchet-and-the-perpetual-motion-gambling-scheme/>)

# Feynman's Brownian Ratchet Motor

Feynman's (Brownian) ratchet: what is it and what was the point of explaining it?

In one sentence:

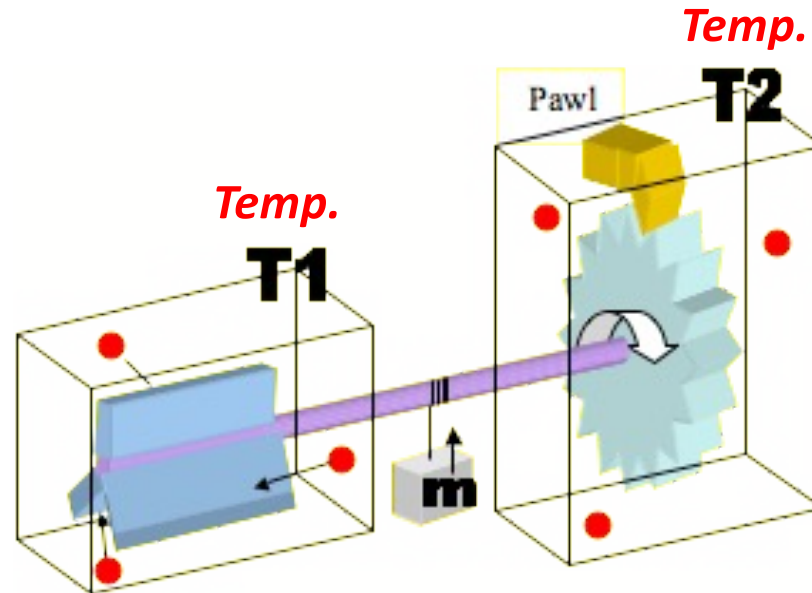

***Where does it go wrong?: Brownian motion also affects the pawl***

***The first moral is the Second Law itself: it is impossible to extract directed motion from a random process (a single heat reservoir). Anyone who claims they can do so is either mistaken or a charlatan.***

From:

<http://gravityandlevity.wordpress.com/2010/12/07/feynmans-ratchet-and-the-perpetual-motion-gambling-scheme/>

# The Feynman Thermal Ratchet

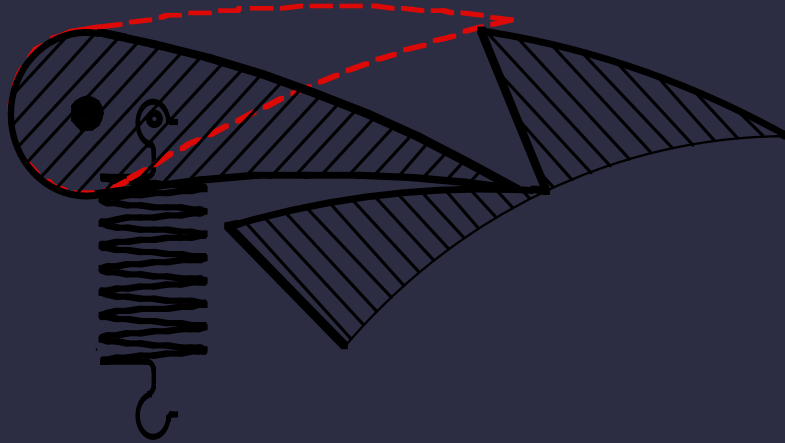

$$P_{\text{forward}} \sim \exp(-\Delta\varepsilon/kT_1)$$

$$P_{\text{backward}} \sim \exp(-\Delta\varepsilon/kT_2)$$

works only if  $T_1 > T_2$  !!

$$\tau_{\text{rel}} \approx CI^2/(4\pi^2\kappa)$$

motor protein conformational change:  $\mu\text{s}$   
 decay of temperature gradient over 10 nm:  $\text{ns}$



wrong  
model

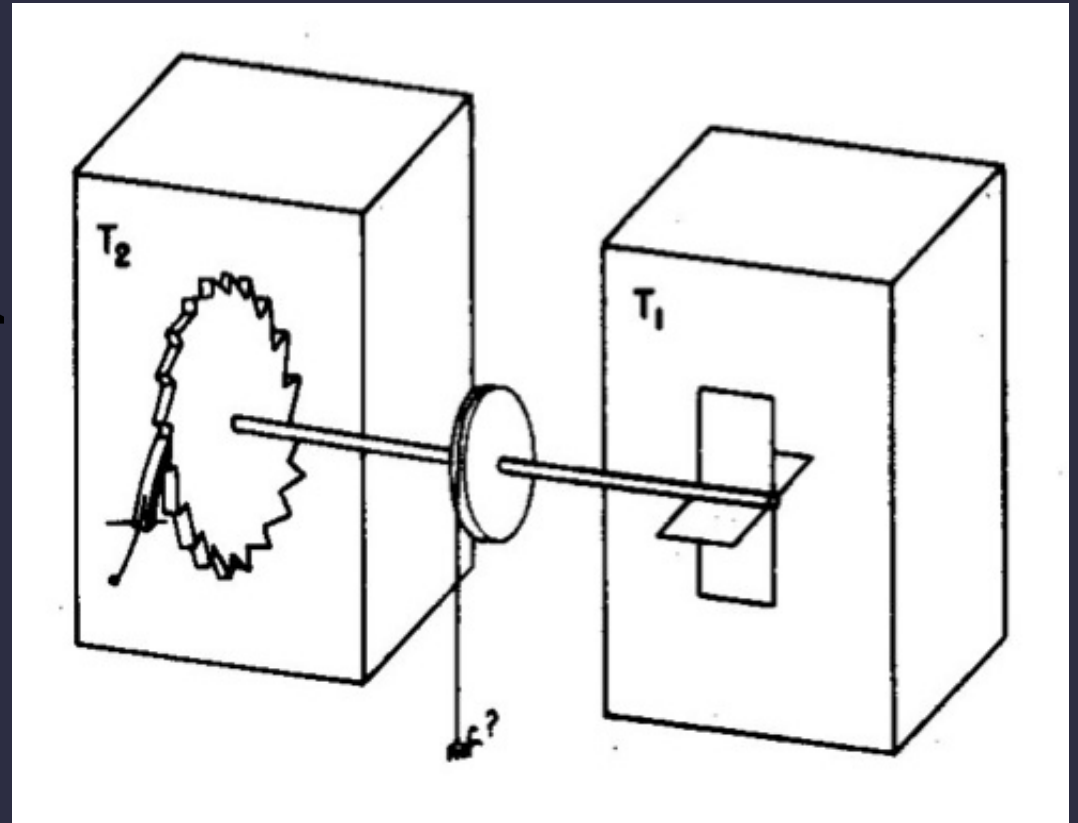

# Feynman's Brownian Ratchet Motor

Although at first sight the Brownian ratchet seems to extract useful work from Brownian motion, Feynman demonstrated that **if the entire device is at the same temperature**, the ratchet will not rotate continuously in one direction but will move randomly back and forth, and therefore will not produce any useful work.

A simple way to visualize how the machine might fail is to remember that the pawl itself will undergo Brownian motion. The pawl therefore will intermittently fail by allowing the ratchet to slip backward or not allowing it to slip forward.

- Feynman demonstrated that if  $T_1 = T_2$ , then pawl failure rate = rate of forward ratcheting,
- So that no net motion results over long enough periods

From Wikipedia:

[http://en.wikipedia.org/wiki/Brownian\\_ratchet](http://en.wikipedia.org/wiki/Brownian_ratchet)

# If you really wanted the thing to work...

- You could make  $T_2 \geq T_1$ , such that the temperature is taken from the temperature gradient....

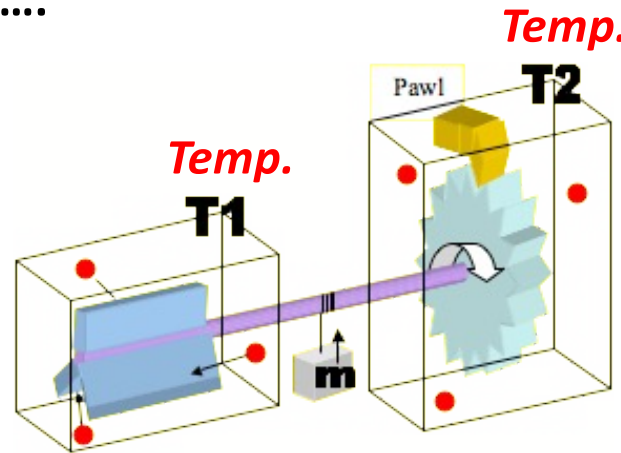

- **BUT YOU JUST DID THE OPPOSITE OF WHAT YOU SAID YOU WANTED TO DO!!**
  - You are using TWO thermal reservoirs! There's also some heat wasted....
  - Wait a minute...this looks like a **mini heat engine** → “a system that performs the conversion of **heat or thermal energy** to **mechanical work** by bringing a working substance from a high temperature state to a lower temperature state”
  - ....which complies with the second law of thermodynamics...which says what?
    - *It is impossible for a device to receive heat from a single reservoir and do a net amount of work.*

# Feynman's Brownian Ratchet Motor

***Where does it go wrong?:***

***=> Brownian motion also affects the pawl !***

The Brownian Ratchet Motor was a 'thought' experiment, along with Maxwell's demon.

It was used *historically* to attempt to explain away the

- 1) potential existence of a molecular machine that can perform....
- 2) perpetual motion, without violating the laws of thermodynamics, namely the conservation of energy and of molecular machines.

In other words, a fraud as Feynman found.... and if anyone tries to convince you otherwise ... just say:

*But, by decree of thermodynamics, Feynman's ratchet cannot work as a heat engine. It plainly violates the Second Law, which says that useful work can only be obtained by the flow of energy from high to low temperature. **This device purports to get energy from a single temperature reservoir: that of the air around it.***

<http://gravityandlevity.wordpress.com/2010/12/07/feynmans-ratchet-and-the-perpetual-motion-gambling-scheme/>

# Reformulated

The goal of these thought experiments was...

- **To prove the nonexistence of a *perpetual motion machine*, or**
- **“a machine which spontaneously converts thermal energy into mechanical work.”**

When the thermal energy is equivalent to the work done, this does not violate the law of *conservation of energy*.

However it does violate the more subtle second law of thermodynamics (see also entropy).

The signature of a perpetual motion machine of the second kind is that there is only ***one heat reservoir involved***, which is being ***spontaneously*** cooled ***without*** involving a transfer of heat to a cooler reservoir.

This conversion of heat into useful work, without any side effect, ***is impossible***, according to the second law of thermodynamics.

From Wikipedia:

[http://en.wikipedia.org/wiki/Perpetual\\_Motion\\_Machine#Classification](http://en.wikipedia.org/wiki/Perpetual_Motion_Machine#Classification)

# Rephrased

- 1. Fallacy:** “Oh, you forgot to take into account friction,” they’ll say, and then they’ll give you a short lecture on the First Law of thermodynamics. “Energy is neither created nor destroyed,” they’ll say.
- 1. Truth:** Most perpetual motion machines that you are likely to encounter ***do not violate energy conservation***. Rather, the tricky and persistent scientific “scams” violate the much more nebulous ***Second Law of Thermodynamics***, which says (in one of its formulations):
  - ***It is impossible for a device to receive heat from a single reservoir and do a net amount of work.***

(From the fun explanation @:

<http://gravityandlevity.wordpress.com/2010/12/07/feynmans-ratchet-and-the-perpetual-motion-gambling-scheme/>)

# So how does this help us?

**=> This means to make a Molecular Motor: we have to introduce this directed energy (for example use of ATP).**

**Which is exactly what scientists did 40 years after Feynman's famous talk!**